

Inhaltsverzeichnis

Angussmühlen:	2
Angussmühlen:	3
Seghers Düsen Ausbrennofen	4
Farbmischanlagen	5
Trockenofen	6
Go Tech Sauger Arburg.....	7
Granulat Entstauber	8
Koch Materialbunker.....	9
Koch CKT 500 Trockner.....	10
IKS Kühlsystem	11
Henn Jansch Temperiergeräte	12
Single Temperiergerät STL 1-9-B5/20-TK6 externer Kühlkreis.....	13
Ausfallweiche Engel.....	14
Nilfisk Sicherheitsindustriesauganlage.....	15
Henn HP 700 Angusspicker.....	16
Henn HS 500 Angusspicker.....	17
Henn HS 500 S Angusspicker	18
Dürrschmidt Handling Portalroboter EG-a4C.....	19
Kleiner Dürrschmidt Angusspicker	20
Helios Patronenheizkörper mit Ummantelung	21
Jumo Itron 16 Temperatur Controller	22
Arburg Luftfilter.....	23
Förderband mit Grünem PVC Band.....	24
Förderband mit Schwarzem PVC Band und Luftstromkühlung.....	25
Fröhlich Band 2 Lagig PVC mit weißer Struktur.....	26
Fröhlich Band Förderanlage mit Steigförderband.....	27
Rau Transportbänder 45° Steigförderband.....	28
Neureder Krauss Maffei LRS 300 Handling.....	29
Knickarm Roboter Yaskawa UP20 XRC	30
EBENFALLS ABB ROBOTER ERHÄLTICH BEI INTERESSE ANFRAGEN	31



Maschinen BOB
ANKAUF & VERKAUF

Angussmühlen:

Getecha GRS A2,29

1.000€

Technische Daten:

Stückzahl: 3
Typ: GRS A2,29
kW: 2,6
Bauj: 04/2002
Mnr.: 13039.2



Maschinen BOB
ANKAUF & VERKAUF

Angussmühlen:

Getecha GRS A1.50

1.500€

Technische Daten:

Stückzahl: 1
 Typ: GRS A1.50
 kW: 2,2-2,5
 Bauj: 10/2001
 Mnr.: 12687,3



ADDA ANTRIEBSTECHNIK GMBH				
63322 RÖDERMARK				
CE				
MOT.3~	C112MI-6	No 9317248		
IP 35	IEC34-5/Hz	50-60	I.Cl.	
kW	Δ V A	Δ A A	cos φ	
2.2	220/380	9.86/5.7	0.78	930
2.2	245/420	9.86/5.7	0.7	990
2.2	220/380	9.51/5.5	0.81	1115
2.55	280/480	9.51/5.5	0.72	1145



Maschinen BOB
 ANKAUF & VERKAUF

Seghers Düsen Ausbrennofen (NEUE BILDER VORHANDEN)

Technische Daten:

2.490€

Baujahr	2002
Volt	220
M.Nr.	410214
Hersteller	Keppel



Maschinen BOB
ANKAUF & VERKAUF

Farbmischanlagen

ACHTUNG VIELE DIESER ANLAGEN BEREITS VERKAUFT

Technische Daten:

Via Anfrage

Stückzahl: 4
Typ TMA8
BJ 2001-2005

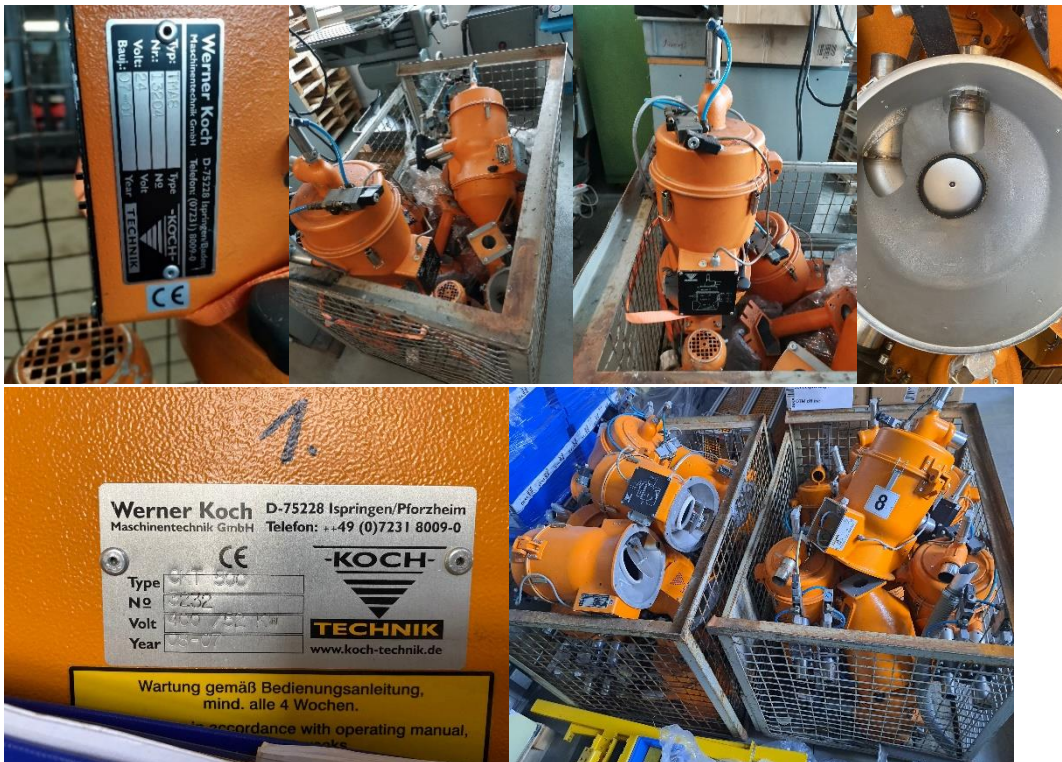

Maschinen BOB
ANKAUF & VERKAUF

info@maschinen-bob.de / m.bullin@fraeser-bob.de / Ansbacherstr. 19 91595 Burgoberbach /
www.maschinen-bob.de

Trockenofen

Technische Daten

1.250 €

Stückzahl	4
Hersteller:	Koch
Baujahr	2004



Maschinen BOB
ANKAUF & VERKAUF

Go Tech Sauger Arburg

Technische Daten:

1.000€

Stückzahl	8
Modell	CHLV 20
Serien Nr.	01210106066
BJ	2006
Volt	230
Hz	50
Watt	10



Maschinen BOB
ANKAUF & VERKAUF

Granulat Entstauber

Technische Daten:

Via Anfrage

Stückzahl 1
Typ S160 Multimat



Maschinen BOB
ANKAUF & VERKAUF

info@maschinen-bob.de / m.bullin@fraeser-bob.de / Ansbacherstr. 19 91595 Burgoberbach /
www.maschinen-bob.de

Koch Materialbunker

Technische Daten:

1.000 €

Stückzahl: 1

Hersteller: Koch

Zustand: gut



Maschinen BOB
ANKAUF & VERKAUF

Koch CKT 500 Trockner

Technische Daten:

3.000 €

Typ	CKT 500
Maschinen	Nr: 3232
Volt:	400 / 52 KW
Baujahr:	2007



Maschinen BOB
ANKAUF & VERKAUF

info@maschinen-bob.de / m.bullin@fraeser-bob.de / Ansbacherstr. 19 91595 Burgoberbach /
www.maschinen-bob.de

IKS Kühlsystem

1.500 €

Baujahr: 2007
Serie: IPC 081
Kältemittel: R407 C
Menge: 5,5 kg
Max Druck: 27,6 bar
Betriebsgewicht: 560 kg



Maschinen BOB
ANKAUF & VERKAUF

Henn Jansch Temperiergeräte

Technische Daten:

800€

Stückzahl	20
Typ	HKG-3-140
Volt	400
Heizk.	3 kW
Temp.max.	140 °C
Systemdruck	6 bar
P	3.25 kW
Wärmemedium	Wasser



Maschinen BOB
ANKAUF & VERKAUF

Single Temperiergerät STL 1-9-B5/20-TK6 externer Kühlkreis

Preis: 1500 €

Technische Daten:

Hz: 50

Herstellungsland und -region: Deutschland

Scheinleistung: 10 kVA

Baujahr: 2007

Leergewicht: 48 kg

IN: 14,7 A

Stromart: 3 ~/PE

UN: 400 V

Wärmeträgermedium: Wasser



Maschinen BOB
ANKAUF & VERKAUF

Ausfallweiche Engel

500 €



Maschinen BOB
ANKAUF & VERKAUF

Nilfisk Sicherheitsindustriesauganlage

3.500 €

Stück: 7
Typ: CTS40 M Z22
Leistung: 4 kW
Leergewicht: 114 kg
Baujahr: 2012-2015



Ex-geschützt

Wurde als Anlagenabsaugung verwendet
Bei Nilfisk diverses zubehör erhältlich (als Saubsauger ebenfalls verwendbar)



Maschinen BOB
ANKAUF & VERKAUF

info@maschinen-bob.de / m.bullin@fraeser-bob.de / Ansbacherstr. 19 91595 Burgoberbach /
www.maschinen-bob.de

Henn HP 700 Angusspicker

Technische Daten:

1.500€

Stückzahl	2
Typ	HP 700
MNr	287061
Volt	24 VDC
Amp	1
Hub	600-650-700-750
Winkel	15-90°



Maschinen BOB
ANKAUF & VERKAUF

Henn HS 500 Angusspicker

Technische Daten:

1.000€

Stückzahl	3
Typ	HS 500
MNr	9955031
Volt	24
AMP	1
Hub	400-450-500-550
Winkel	15-90°



Maschinen BOB
ANKAUF & VERKAUF

Henn HS 500 S Angusspicker

Technische Daten:

1.000€

Stückzahl	2
Typ	HS 500 S
MNr	2754023
Volt	24V
Amp	1
Hub	400-450-500-550
Winkel	15-90°



Maschinen BOB
ANKAUF & VERKAUF

Dürschmidt Handling Portalroboter EG-a4C

Technische Daten:

2.500€

Dürschmidt Handling Handhabungssystem Portal Roboter mit Pneumatischer Steuerung

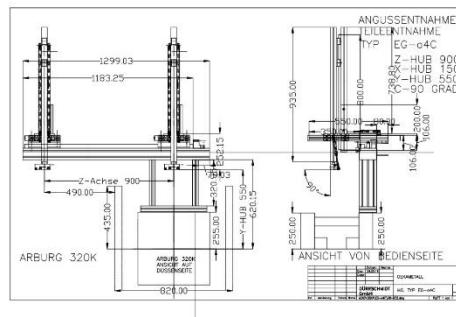
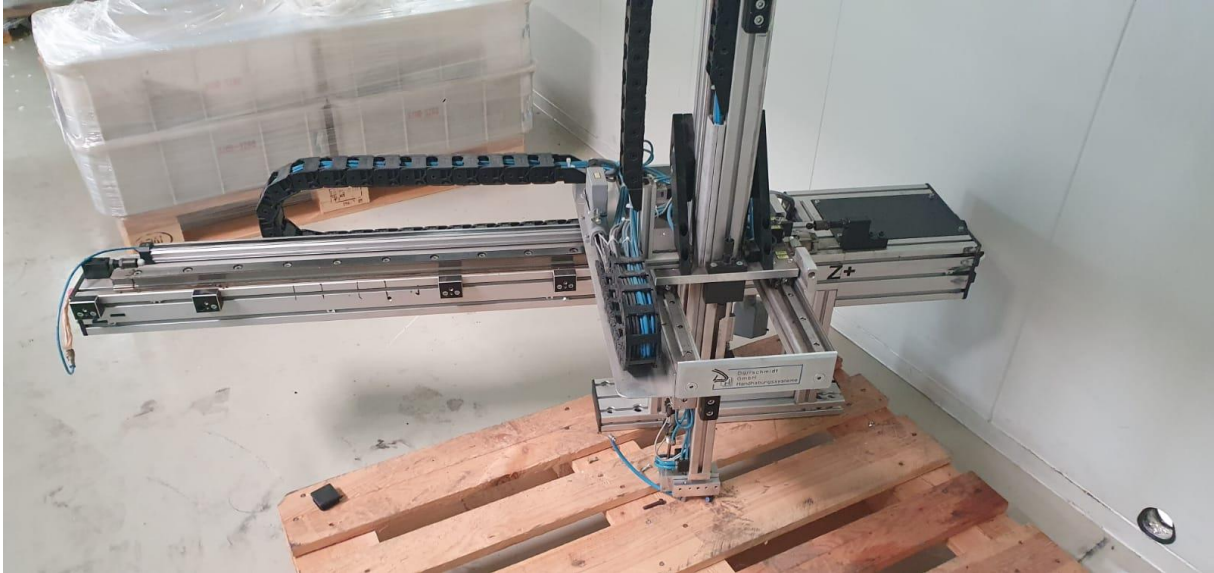

Maschinen BOB
ANKAUF & VERKAUF

Kleiner Dürschmidt Angusspicker

Technische Daten:

1.000

Dürschmidt Handling Handhabungssystem Portal Roboter mit Pneumatischer Steuerung

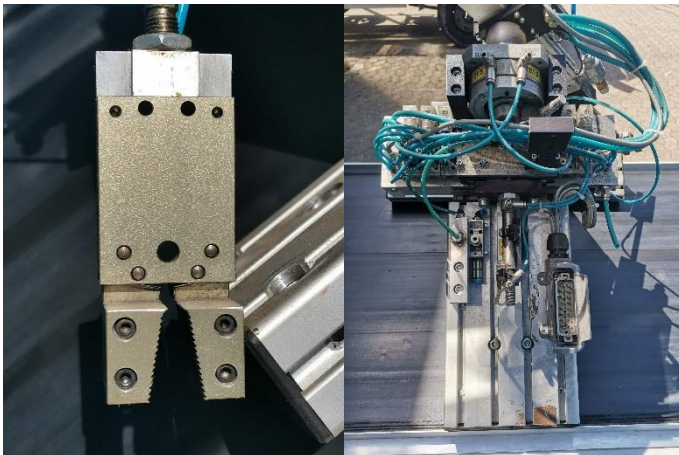
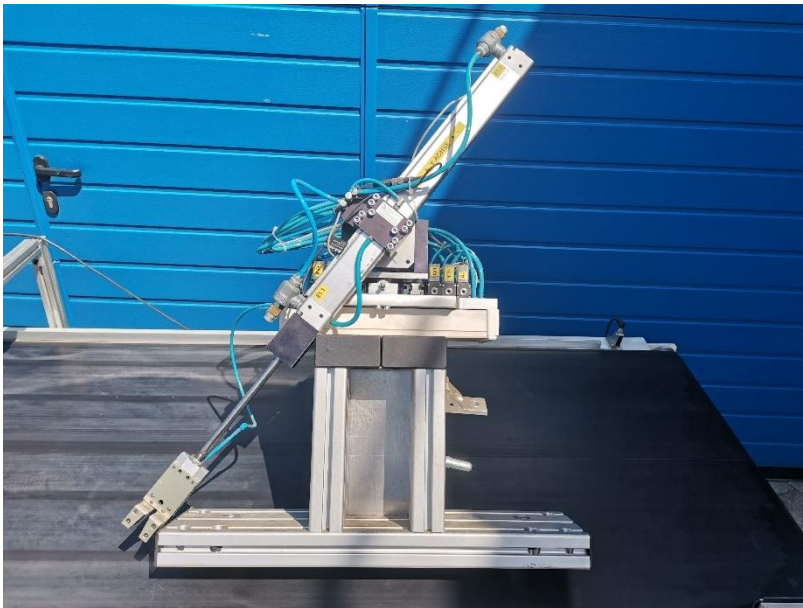

Maschinen BOB
ANKAUF & VERKAUF

Helios Patronenheizkörper mit Ummantelung

Technische Daten:

300 €

Stückzahl	10
Artikel Nr.	24029022
Hersteller:	Helios
Volt	230
Watt	1500
Baujahr	2001



Maschinen BOB
ANKAUF & VERKAUF

Jumo Itron 16 Temperatur Controller

Technische Daten

250 €

Stückzahl	7
Marke	Electrolux
Temp	200-1300 °C



Maschinen BOB
ANKAUF & VERKAUF

Arburg Luftfilter

1.250€

Stück

16



Maschinen BOB
ANKAUF & VERKAUF

info@maschinen-bob.de / m.bullin@fraeser-bob.de / Ansbacherstr. 19 91595 Burgoberbach /
www.maschinen-bob.de

Förderband mit Grünem PVC Band

Technische Daten:

1.500 €

Hz	50
kW	0,22
Gewicht	ca 40 kg
Bandgröße	L 206
	B 50
	H 97,5



Maschinen BOB
ANKAUF & VERKAUF

Förderband mit Schwarzem PVC Band und Luftstromkühlung

Technische Daten

1.750 €

Volt	230
kW	0,12
Hz	50
1/min min	34
1/min max	1350



Maschinen BOB
ANKAUF & VERKAUF

Fröhlich Band 2 Lagig PVC mit weißer Struktur

Technische Daten:

1.500 €

Stückzahl 2

2600 mm * 250 mm

Beidseitige Blockleiste 4*8

Kantenbündig

26 Stollen

T 10 Strukturiert

K 10 mittig Laufseite



Maschinen BOB
ANKAUF & VERKAUF

info@maschinen-bob.de / m.bullin@fraeser-bob.de / Ansbacherstr. 19 91595 Burgoberbach /
www.maschinen-bob.de

Fröhlich Band Förderanlage mit Steigförderband

Technische Daten:

2.500 €

Stückzahl:2

Mit dieser Anlage wurden Bürsten gefördert und
per Druckluft aussortiert

Das Gerät hat wenig Betriebsstunden und ist in einem
Sehr guten Zustand



Maschinen BOB
ANKAUF & VERKAUF

Rau Transportbänder 45° Steigförderband

Technische Daten

1.500 €

Stückzahl:2

M Nr:45927-1,2 // 45927-1.5

BJ: 2004



Maschinen BOB
ANKAUF & VERKAUF

Neureder Krauss Maffei LRS 300 Handling

Technische Daten:

5.000 €

Typ LRS 300

KMK Serien Nr.:61011404

Baujahr:05/2008

Volt: 3x400V

Hz:50Hz, 3PH mit NL

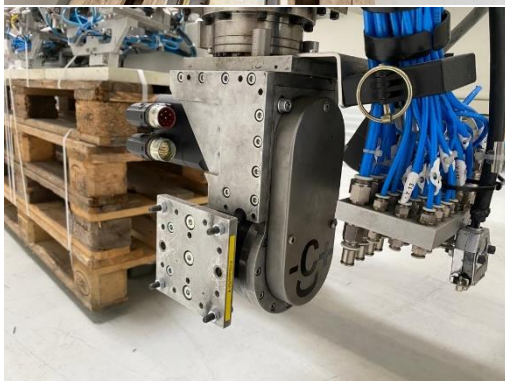
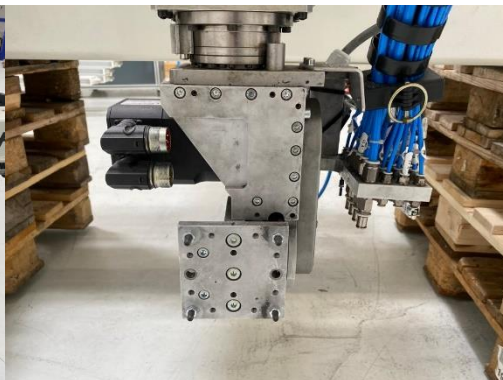
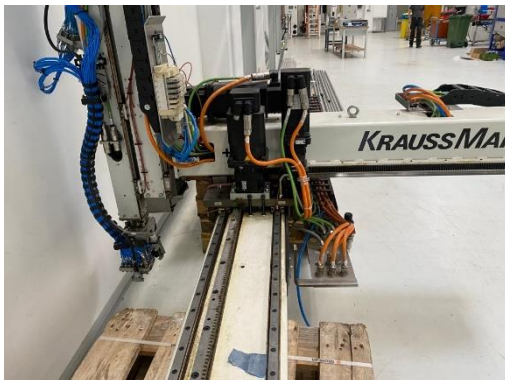

Maschinen BOB
ANKAUF & VERKAUF

Knickarm Roboter Yaskawa UP20 XRC

5.000 €

Stück: 5 Komplet 4 als ersatzteilträger verfügbar

Typ: UP20 XRC

Baujahr: 2004

Bedienpanel Typ: JZNC-XPP02B

Die Roboter wurden als Automation an Arburg Anlagen verwendet

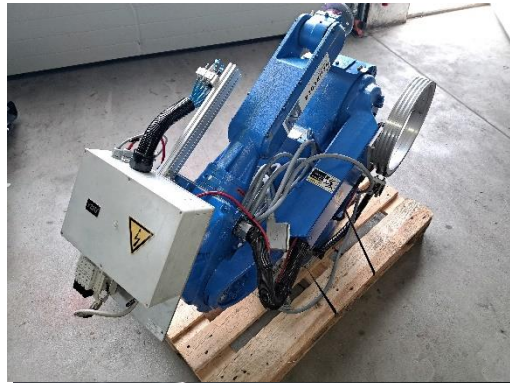

Maschinen BOB
ANKAUF & VERKAUF

EBENFALLS ABB ROBOTER ERHÄTLICH
BEI INTERESSE ANFRAGEN



Maschinen BOB
ANKAUF & VERKAUF